



# LEADER 3



British designed and  
built for British farmers



Shown with 3000L tank and 24m boom



## STANDARD FEATURES

### Controls



**Computerised spray rate controller** automatically adjusts spray application rate to forward speed. The Muller system shown also controls boom hydraulics and steering system from either the main screen or joystick (supplied).



**Hydraulic and spray functions** are mounted at the rear and protected by a moulded cover.



**Work station** controlling primary functions to operate the sprayer and when cleaning or filling.



**Chemical induction:** 25L stainless steel hopper for safe transfer of liquids and powders via a high pressure venturi system to the main tank, a rotary nozzle for cleaning containers.



**Diaphragm pump:** High quality poly' series to withstand any aggressive plant protection chemicals.



**Viewing platform** with folding steps provide access to main tank.



**Clothes storage:** Clothing and PPE locker.



**Clean water supply:** 20L for hand wash and 350L for cleaning and boom flushing.



**Axle suspension** absorbs the shock loads instead of transferring them to the main chassis or boom. 1m ground clearance.

### Booms



**Boom construction:** All booms are manufactured from steel tubular sections. The three dimensional structure guarantees strength and durability.

All nozzles and spray lines are secured above the base of the boom for protection against accidental damage.



**Boom adjustment:** All pivot points and fold rams can be adjusted to counteract wear.

**Pantograph boom lift system** ensures excellent stability and performance, damped by a nitrogen accumulator. Boom adjustment height from 500 to 2500mm.



**Boom stowage system:** Secures boom assembly in the folded position for safe road transport.



**'Break back'** boom design is a standard feature on all models to avoid damage from unseen obstructions.



**Boom flexibility:** it is possible to work with the boom part-folded:

<b>2 fold</b>	<b>3 fold</b>
18 to 9m	28 to 12m
20 to 11m	30 to 12m
21 to 11m	32 to 12m
24 to 12m	

### Other Standard Fittings

- Hydraulic boom tilt
- Tank fill
- Road lighting & brakes
- Retractable hose reel for cleaning
- Dry tank level sight gauge

## OPTIONAL EXTRAS



**Tracking/steering drawbar** ensures the wheels of the sprayer follow in the 'wheelings' of the tractor to minimise crop damage. Manual and automatic field modes plus road transport mode with ram locking device.



**Variable boom geometry** enables the operator to individually lift either side of the boom to match contoured land. (shown here on a mounted Team sprayer)

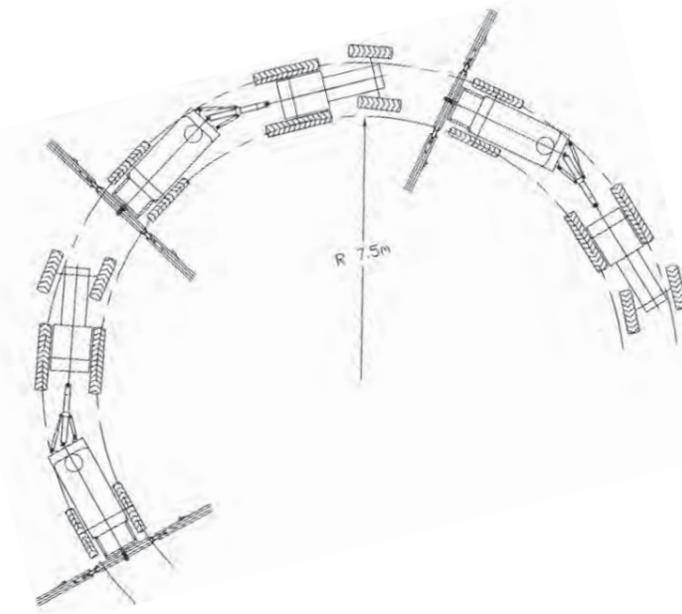

### Other Optional Extras

- Boom re-circulation (compressed air shut-off)
- GPS boom section switching
- Air-ride suspension
- Stainless steel spray lines
- Bout/foam maker
- One-side boom fold (outer section only)
- Triple nozzle assemblies enable the operator to select from a choice of 3 nozzle sizes for various applications
- Fast fill pump hydraulically driven 2" 700L/min pump for main tank fill or tank pump out



# Leader 3

## TECHNICAL SPECIFICATIONS

Item	Dimension
Tank capacities [L]	2500, 3000, 3500, 4000
Pumps (type / L per min)	Poly 2180 /180; Poly 2250 / 250
Boom lengths [m]	18, 20, 21, 24, 28, 30, 32
Hydraulic outlet required	one double acting
Weight - draw bar, empty [Kg]	840
Weight - axle, empty [Kg]	2720
Weight - total* ,empty [Kg]	3560
Turning radius [m]	7.00
Total height [m]	3.30 [with boom folded]
Width up to 24m [m]	2.70
Width 28 - 30m [m]	3.1
Length draw bar to axle [m]	4.15 Steering draw bar
Clearance [m] 12.4 x 46	1.00
Rinse tank [L]	300 or 400

**Notes:** The Leader 3 is available with a range of booms from 18 to 32m [28, 30 and 32m are tri-fold].

All booms have pendulum suspension and anti-yaw damping. The Leader 3 chassis and boom have been designed to meet the rigorous demands of any farming environment.

We reserve the right to improve machine specification without prior notice.

\*Weight shown for 3500 litre tank with 28m boom.

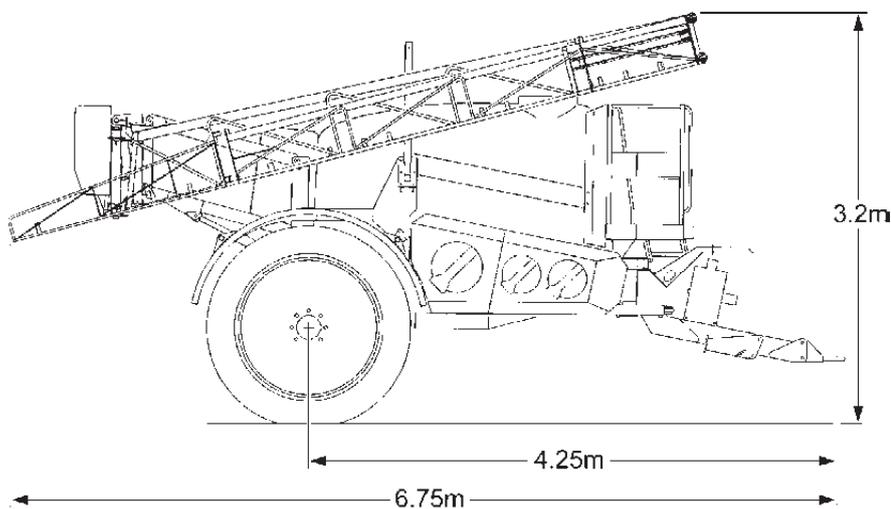

3000L with 24m boom and standard drawbar



Leaders in the field of application

Team Sprayers Ltd  
Unit 3 Lancaster Way Business Park,  
Witchford, Ely, Cambridgeshire CB6 3NW

E [sales@team-sprayers.com](mailto:sales@team-sprayers.com) 

[team-sprayers.com](http://team-sprayers.com) • 01353 661211



# LEADER 4



British designed and  
built for British farmers



Shown with 4000L tank and 24m boom



## STANDARD FEATURES

### Controls



**Computerised spray rate controller** automatically adjusts spray application rate to forward speed. The Muller system shown also controls boom hydraulics and steering system from either the main screen or joystick (supplied).



**Hydraulic and spray valves** are mounted at the rear and protected by a moulded cover.



**Boom re-circulation:** compressed air shut-off.



**Work station** controlling primary functions to operate the sprayer and when cleaning or filling.



**Chemical induction:** 25L stainless steel hopper for safe transfer of liquids and powders via a high pressure venturi system to the main tank, a rotary nozzle for cleaning containers.



**Diaphragm pump:** High quality Poly' series to withstand any aggressive plant protection chemicals.



**Viewing platform** provides access to main tank.



**Clothes storage:** Clothing and PPE lockers.



**Clean water supply:** 20L for hand wash and 350L for cleaning and boom flushing.



**Axle air suspension** absorbs the shock loads instead of transferring them to the main chassis or boom.

### Booms



**Boom construction:** All booms are manufactured from steel tubular sections. The three dimensional structure guarantees strength and durability.

All nozzles and spray lines are secured above the base of the boom for protection against accidental damage.



**Boom adjustment:** All pivot points and fold rams can be adjusted to counteract wear.



**Pantograph boom lift system** ensures excellent stability and performance, damped by a nitrogen accumulator. Boom adjustment height from 500 to 2500mm.



**Boom stowage system:** Secures boom assembly in the folded position for safe road transport.

**'Break back'** boom design is a standard feature on all models to avoid damage from unseen obstructions.



**Boom flexibility:** it is possible to work with the boom part-folded:

2 fold	3 fold
18 to 9m	28 to 12m
20 to 11m	30 to 12m
21 to 11m	32 to 12m
24 to 12m	

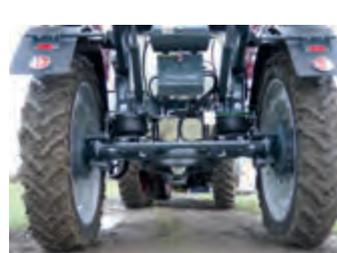

**Tracking/steering axle** ensures the wheels of the sprayer follow in the 'wheelings' of the tractor to minimise crop damage. Manual / automatic field modes.

## OPTIONAL EXTRAS



**Fast fill pump** hydraulically driven 2" 700L/min pump for main tank fill or tank pump out.

**Retractable hose reel and lance kit** for cleaning down

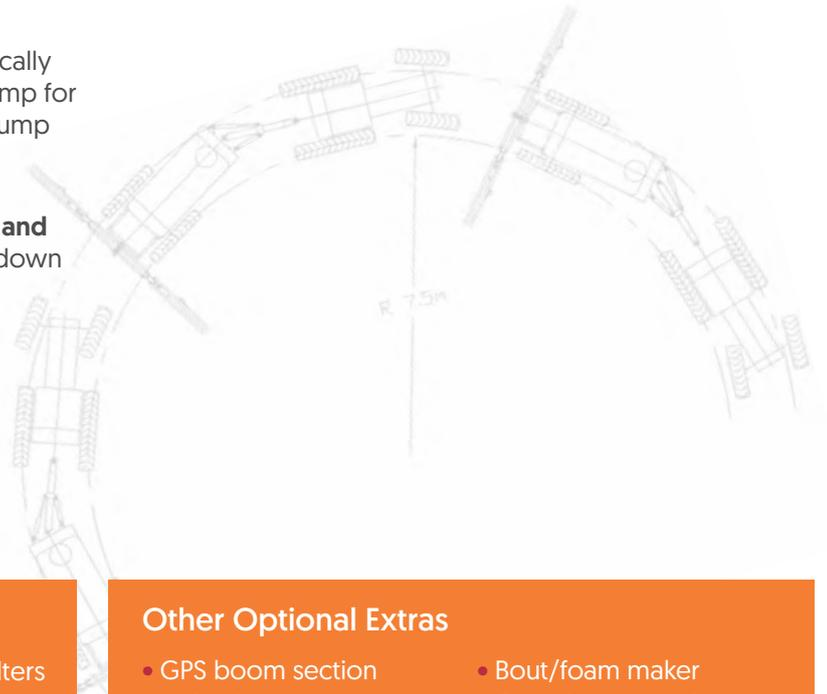

### Other Standard Fittings

- Hydraulic boom tilt
- Road lighting & brakes
- Dry tank level sight gauge
- Spray boom in-line filters
- Triple nozzles

### Other Optional Extras

- GPS boom section switching and mapping
- Stainless steel spray lines
- Bout/foam maker
- One-side boom fold (outer section only)



# Leader 4

## TECHNICAL SPECIFICATIONS

Item	Dimension
Tank capacities [L]	3000, 4000, 5000
Pumps (type / L per min)	Poly 2180 /180; Poly 2250 / 250
Boom lengths [m]	18, 20, 21, 24, 28, 30, 32
Hydraulic outlet required	one double acting
Weight - draw bar, empty [kg]	840
Weight - axle, empty [kg]	2720
Weight - total*, empty [kg]	3560
Turning radius [m]	7.00
Total height [m]	3.30 [with boom folded]
Width up to 24m	2.70m
Width 28 - 30m	3.1m
Length draw bar to axle [m]	4.30 Steering draw bar
Clearance 12.4 x 46 wheels [m]	0.76
Rinse tank [L]	300 or 400

**Notes:** The Leader 4 is available with a range of booms from 18 to 32m [28, 30 and 32m are tri-fold].

All booms have pendulum suspension and anti-yaw damping. The Leader 4 chassis and boom have been designed to meet the rigorous demands of any farming environment.

We reserve the right to improve machine specification without prior notice.

\*Weight shown for 3000 litre tank with 24m boom.

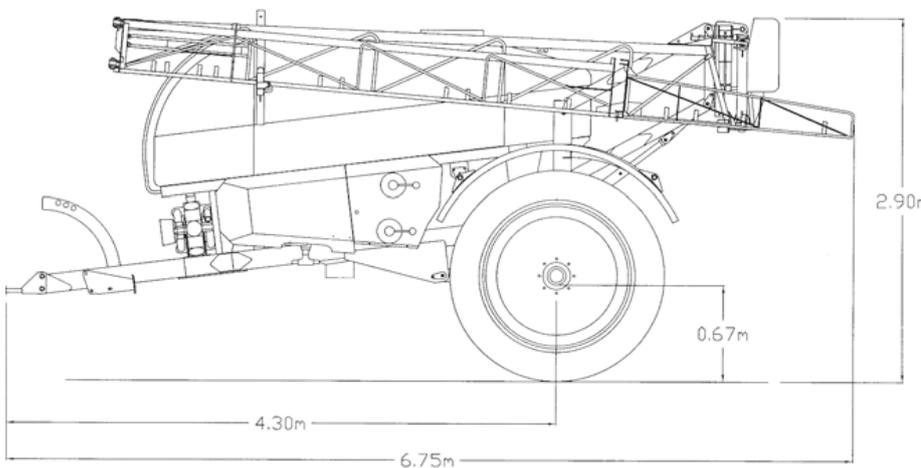

4000L with 24m boom and standard drawbar



Leaders in the field of application

Team Sprayers Ltd  
Unit 3 Lancaster Way Business Park,  
Witchford, Ely, Cambridgeshire CB6 3NW

E [sales@team-sprayers.com](mailto:sales@team-sprayers.com) 

[team-sprayers.com](http://team-sprayers.com) • 01353 661211